

HYUNDAI INFRACORE GENERATOR ENGINE

P126TI

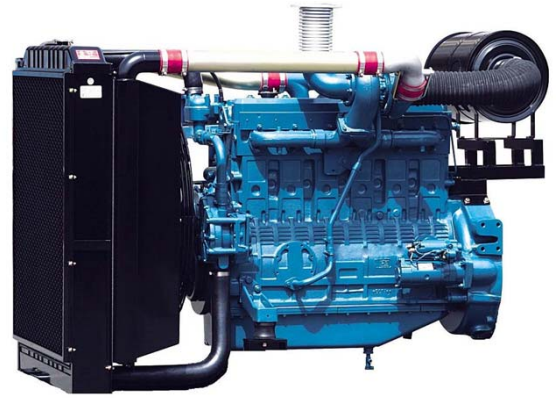

Ratings (kWm/PS)	Gross Engine Output		Net Engine Output	
	Standby	Prime	Standby	Prime
1500rpm(50Hz)	272/370	241/328	265/360	234/318
1800rpm(60Hz)	298/405	278/378	287/390	267/363

Ratings Definitions

The power ratings of Emergency Standby and Prime are in accordance with ISO 8528.

Fuel Stop power in accordance with ISO 3046.

Electric power (kWe) must be considered cooling fan loss, alternator efficiency, altitude derating and ambient temperature.

STANDBY POWER RATING is applicable for supplying emergency power for the duration of the utility power outage.

No overload capability is available for this rating. A standby rated engine should be sized for a maximum of an 80% average load factor and 200 hours of operation per year. This includes less than 25 hours per year at the Standby Power rating.

PRIME POWER RATING is available for an unlimited number of hours per year in variable load application. Variable load should not exceed a 70% average of the Prime Power rating during any operating period of 24 hours. The Total operating time at 100% Prime Power shall not exceed 500 hours per year. A 10% overload capability is available for a period of 1 hour withing a 12 hour period of operation. Total operating time at the 10% overload power shall not exceed 25 hours per year.

◎ GENERAL ENGINE DATA

○ Engine Model	P126TI
○ Engine Type	4-Cycle, In-line, 6-Cylinder Diesel, water cooled, Turbo charged & intercooled
○ Bore x stroke	123 x 155 mm
○ Displacement	11.051 liters
○ Compression ratio	17.1 : 1
○ Rotation	Counter clockwise viewed from Flywheel
○ Firing order	1-5-3-6-2-4
○ Injection timing	16°±1° BTDC
○ Dry weight	910kg (with Fan)
○ Dimension (LxWxH)	1,384 x 1,109 x 1,195 mm
○ Fly wheel housing	SAE NO.1M
○ Fly wheel	Clutch NO.14M
○ Number of teeth on flywheel	152

◎ ENGINE MOUNTING

Maximum Bending Moment at Rear Face to Block	1325 N · M
--	------------

◎ EXHAUST SYSTEM

Maximum Back Pressure	5.9 kPa
-----------------------	---------

◎ AIR INDUCTION SYSTEM

Maximum Intake Air Restriction	
. With Clean Filter Element	2.16 kPa
. With Dirty Filter Element	6.23 kPa
○ Max. static pressure after Radiator	0.125 kPa

◎ COOLING SYSTEM

Water circulation by centrifugal pump on engine.

○ Cooling method	Fresh water forced circulation
○ Coolant capacity	Engine Only : Approx. 19 lit., With Radiator : Approx. 51 lit. (standard)
○ Coolant flow rate	liters / min
○ Pressure Cap	49 kPa
○ Water Temperature	
- Maximum for standby and Prime	103 °C
- Before start of full load	40.0 °C
○ Water pump	Centrifugal type driven by Gear
○ Thermostat Type and Range	Wax – pellet type, Opening temp. 71 °C , Full open temp. 85 °C
○ Cooling fan	Blower type, Plastic , 755 mm diameter, 7 blade
○ Max. external coolant system restriction	Not available

◎ LUBRICATION SYSTEM

Force-feed lubrication by gear pump, lubricating oil cooling in cooling water circuit of engine.

○ Lub. Method	Fully forced pressure feed type
○ Oil pump	Gear type driven by crank-shaft gear
○ Oil filter	Full flow, cartridge type
○ Oil capacity	Max. 23 liters , Min. 20 liters
○ Lub oil pressure	Idle Speed : Min 100 kPa Governed Speed : Min 250 kPa
○ Maximum oil temperature	120 °C
○ Angularity limit	Front down 10 deg , Front up 10 deg , Side to side 22.5 deg
○ Lubrication oil	Refer to Operation Manual

◎ FUEL SYSTEM

Bosch type in-line pump with integrated, electromagnetic actuator.

○ Injection pump	Zexel in-line "P" type
○ Governor	Electric type (all speed control)
○ Speed drop	G2 Class (ISO 8528)
○ Feed pump	Mechanical type in injection pump
○ Injection nozzle	Multi hole type
○ Opening pressure	21.1 MPa
○ Fuel filter	Full flow, cartridge type with water drain valve
○ Maximum fuel inlet restriction	10 kPa
○ Maximum fuel return restriction	60 kPa
○ Fuel feed pump Capacity	230 liters / hr
○ Used fuel	Diesel fuel oil

◎ ELECTRICAL SYSTEM

○ Battery Charging Alternator	28.5V x 45A alternator
○ Voltage regulator	Built-in type IC regulator
○ Starting motor	24V x 6.0 kW
○ Battery Voltage	24V
○ Battery Capacity	150 Ah (recommended)
○ Starting aid (Option)	Block heater

◎ VALVE SYSTEM

○ Type	Overhead valve type	
○ Number of valve	Intake 1, exhaust 1 per cylinder	
○ Valve lash at cold	Intake 0.3mm , Exhaust 0.3mm	
○ Valve timing	Opening	Close
- Intake valve	18 deg. BTDC	34 deg. ABDC
- Exhaust valve	46 deg. BBDC	14 deg. ATDC

◎ PERFORMANCE DATA

		Prime Power		Standby Power	
○ Governed Engine speed	rpm	1500	1800	1500	1800
○ Engine Idle Speed	rpm	800	800	800	800
○ Over speed limit	rpm	1650	1980	1650	1980
○ Gross Engine Power Output	kW	241	278	272	298
	ps	328	378	370	405
○ Break Mean effective pressure	Mpa	1.75	1.68	1.97	1.80
○ Mean Piston Speed	m/s	7.75	9.3	7.75	9.3
○ Friction Power	kW	24	33	24	33
	ps	32.63	44.87	32.63	44.87
○ Specific fuel consumption					
25% load	liters/hr	16.4	20.3	18.3	21.5
50% load	liters/hr	30.0	36.2	33.4	38.7
75% load	liters/hr	43.6	52.3	49.1	56.3
100% load	liters/hr	58.1	70.3	66.2	76.5
○ Fan Power	kW	7	11	7	11
○ Sound Pressure at 1m from the each side of Cylinder Block					
(without Fan)	dB(A)	96.5	97.5	96.5	97.5

The all data and the specific fuel consumption are based on ISO 3046/1, Standard reference conditions are in accordance with 298 K(25° Celsius) air temperature, 100kPa(1000mbar) air pressure, 60% relative humidity, 110m(361ft) altitude.

Operation At Elevated Temperature And Altitude: The engine may be operated at :

1800 rpm & 1500rpm up to 750~ 1000m and 30°C without power deration

For sustained operation above these conditions, derate by 3% per 304m , and 2% per 11 °C

Engine Data with Dry Type Exhaust Manifold

○ Intake Air Flow	m3/min	19.35	26.53	21.09	27.68
○ Exhaust gas temp. after turbo.	°C	560	510	593	540
○ Exhaust Gas Flow	m3/min	42.9	58.1	49.7	67.3
○ Heat Rejection to Exhaust	kW	204.7	247.7	233.3	269.6
○ Heat Rejection to Coolant	kW	89.0	107.7	101.4	117.2
○ Heat Rejection to Intercooler	kW	47.5	57.4	54.1	62.5
○ Radiated Heat to Ambient	kW	20.8	25.1	23.7	27.3
○ Cooling water circulation	liters/min	265	320	265	320
○ Cooling fan air flow	m3/min	370	433	370	433

◆ ENGINE DIMENSION

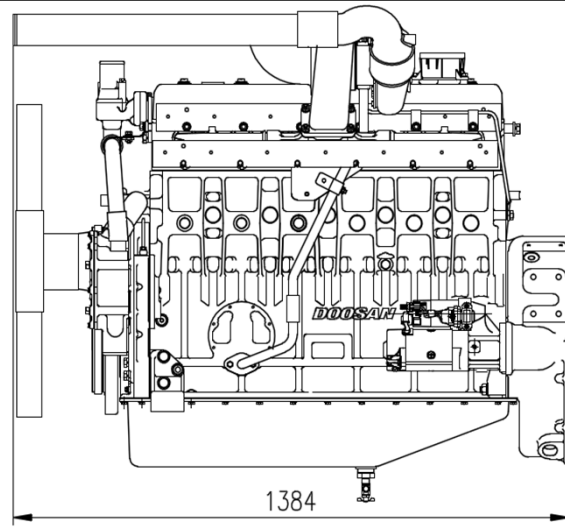
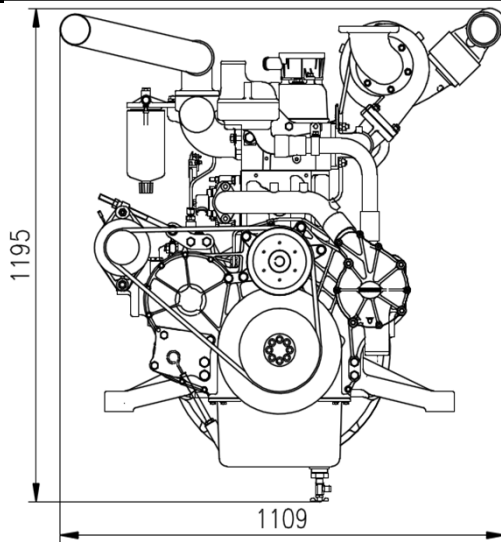

◆ CONVERSION TABLE

in. = mm x 0.0394

PS = kW x 1.3596

psi = kg/cm² x 14.2233

in³ = lit. x 61.02

hp = PS x 0.98635

lb = kg x 2.20462

kW = Kcal/sec x 0.239

lb/ft = N.m x 0.737

U.S. gal = lit. x 0.264

kW = 0.2388 kcal/s

lb/PS.h = g/kW.h x 0.00162

cfm = m³/min x 35.336

Mpa = Pa x 1000 = bar x 10

HD Hyundai Infracore Co., Ltd.

13F, HD Hyundai Global R&D Center, 477, Bundangsuseo-ro,
Bundang-gu, Seongnam-si, Gyeonggi-do, Republic of Korea, Korea.
(13553)

E-mail : enginesales@hyundai-di.com

Web site : www.hd-hyundaiengine.com

※ Specifications are subject to change without prior notice